

Комплекс инженерных решений
для машиностроения



Более 15 лет на рынке



КОМАНДА ПРОФЕССИОНАЛОВ



GMN



**РЕМОНТ
ШПИНДЕЛЬНЫХ
УЗЛОВ**

**РЕМОНТ
И МОДЕРНИЗАЦИЯ
СТАНКОВ**



Производственная площадка

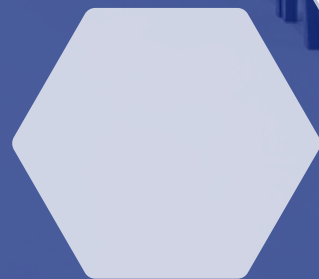



ЗОНА ПРИЕМКИ

ШПИНДЕЛЬНЫХ УЗЛОВ



ЗОНА СБОРКИ И РАЗБОРКИ ШПИНДЕЛЬНЫХ УЗЛОВ



УЧАСТОК БАЛАНСИРОВКИ



ЗОНА СТЕНДОВЫХ ИСПЫТАНИЙ



ЦЕХ МЕТАЛЛОБРАБОТКИ

НАШИ КЛИЕНТЫ



НЕОБХОДИМЫЙ КОМПЛЕКС РЕМОНТНЫХ РАБОТ

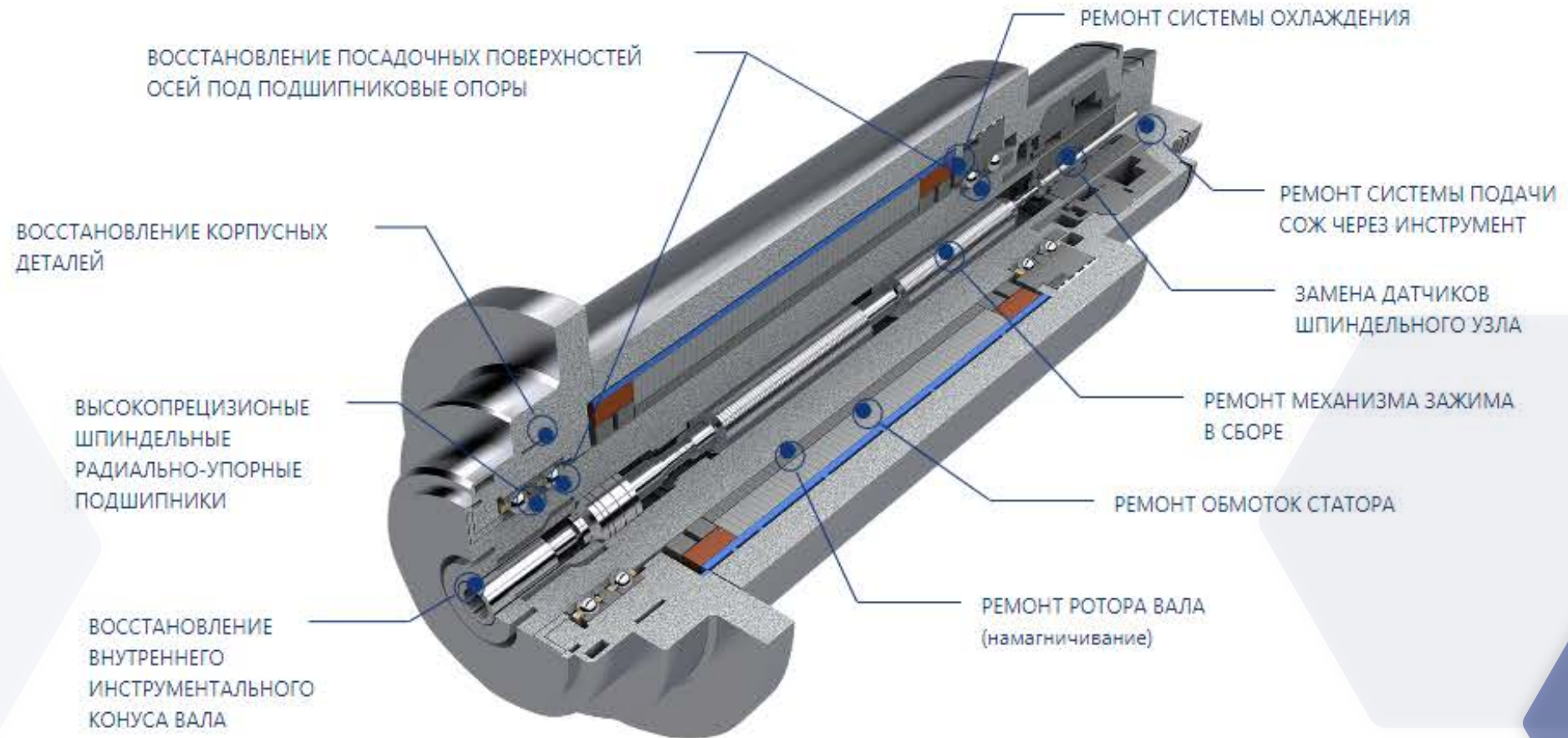

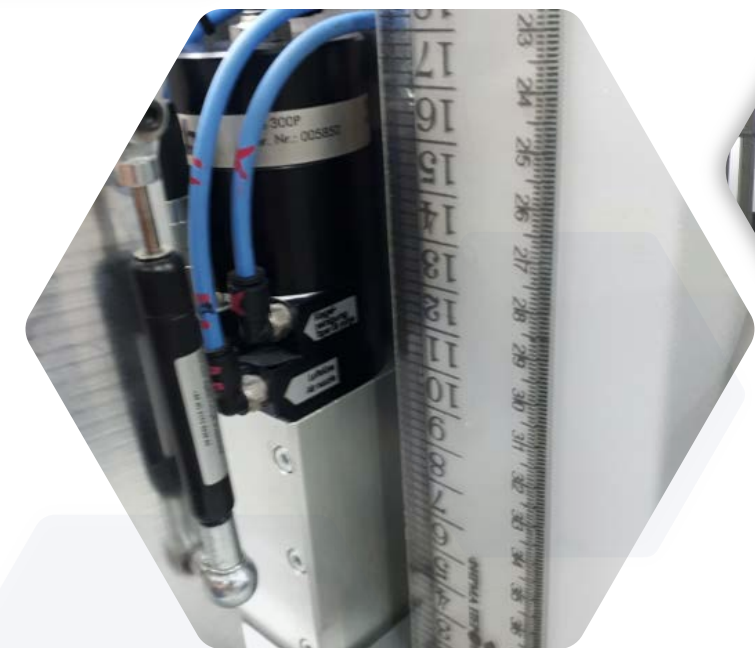

БОЛЕЕ 1 500
ШПИНДЕЛЬНЫХ УЗЛОВ **ОТРЕМОНТИРОВАННО**
от миниатюрных до самых больших

до модернизации

Проведена модернизация
более 60-ти единиц
шлифовального
оборудования



после модернизации

МОДЕРНИЗАЦИЯ СТАНКОВ

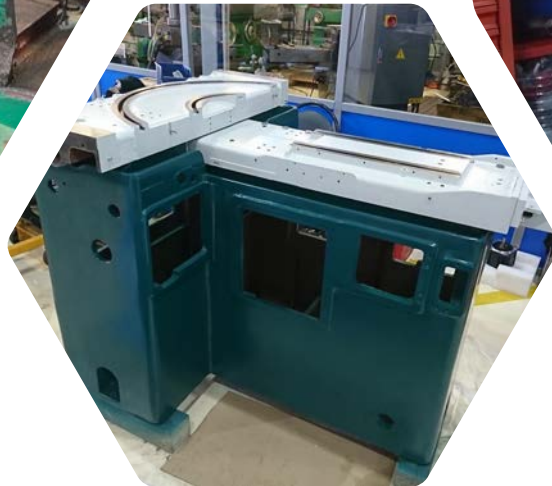

СЕРТИФИКАТЫ



Агентское соглашение

Настоящим соглашением мы подтверждаем что компания Euroschiff является полным агентом по России компании BERG по производству и продаже: «Шпиндели для турбины», «Шпиндели автомобильные», «Шпиндели авиационные».

BERG & Co. GmbH

Klaus Wehinger
General Manager

Frank Kuskeberg
General Manager

Bielefeld, 12.02.2019, February 2019

Seite 1 von 1

Berg & Co. GmbH 10000 Bielefeld 41 Germany	Telephone: +49 5203 178-0 Fax: +49 5203 178-110 E-Mail: info@berg-spanntechnik.de Website: www.berg-spanntechnik.de	Commercial AD Bielefeld 10000 Bielefeld 41 Germany Telephone: +49 5203 178-0 Fax: +49 5203 178-110 E-Mail: info@berg-spanntechnik.de Website: www.berg-spanntechnik.de	Spinnaker Bearings 10000 Bielefeld 41 Germany Telephone: +49 5203 178-0 Fax: +49 5203 178-110 E-Mail: info@berg-spanntechnik.de Website: www.berg-spanntechnik.de
---	---	--	---

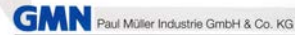

Agency Agreement

between

GMN Paul Müller Industrie GmbH & Co. KG
Aussere Bayreuther Str. 230
D-90411 Nuremberg

(following called „GMN“)

and

ООО „ЕУРОШЛИФ“
Ул. Котлыковская 7/8
115201 Москва, Russland

(following called „Euroschiff“)

for **Russian Federation**

concerning

High Precision Ball Bearings

Machine Spindles
and all other types of Spindles manufactured
by GMN

(following called 'products')



1. GMN appoints Euroschiff to its exclusive representation for the above mentioned territory and products.
2. This agreement is valid until 31st December 2010.

If the agreement is not terminated, it will continue until notice is given by either party in writing by registered mail three months before the end of the calendar year (December 31).
3. Euroschiff will buy products from GMN and sell the products to the customers.
4. GMN is permitted to sell the products directly to anyone on the market. In such a case GMN will inform Euroschiff and pay a commission.
5. It is Euroschiff's obligation not to sell or to represent similar goods of competitors without permission of GMN.

Nuremberg, June 17th, 2008

GMN Paul Müller Industrie GmbH & Co. KG
Aussere Bayreuther Str. 230
D-90411 Nuremberg

Michael Lösch (President)

Euroschiff
Котлыковская Стр. 7/8
115201 Москва

Belousov Denis



ООО „ЕУРОШЛИФ“
ул. Котлыковская д. 7/8
115201, г. Москва
Россия

Your REF.: Denis Belousov
Dated: 24.05.2012
Contact: Konstantin Posehn
Direct: +49 911 56 91 224
Fax: +49 911 56 91 699
E-mail: k.posehn@gmn.de
Date: 24.05.2012

GMN Maching Spindles Confirmation

We **GMN Paul Müller Industrie GmbH & Co. KG**
whose registered office is at **Außere Bayreuther Str. 230**
D-90411 Nuremberg

confirm that **ООО „ЕУРОШЛИФ“**
whose registered office is at **ул. Котлыковская д. 7/8**
115201, г. Москва
Россия

to be our only official Agent for the whole GMN Production Range of Spindles in the territory of Russia.

GMN
Paul Müller Industrie GmbH & Co. KG
Außere Bayreuther Str. 230
D-90411 Nuremberg

Paul Müller Industrie GmbH & Co. KG Aussere Bayreuther Str. 230 D-90411 Nuremberg Germany Telephone: +49 (0) 911 5691-0 Fax: +49 (0) 911 5691-110 E-Mail: info@gmn.de Website: www.gmn.de Banking account: www.gmn.de	Legal Representative: Konstantin Posehn Aussere Bayreuther Str. 230 D-90411 Nuremberg Germany Telephone: +49 (0) 911 5691-224 Fax: +49 (0) 911 5691-699 E-Mail: k.posehn@gmn.de
---	--



SALES REPRESENTATIVE AGREEMENT (THE AGREEMENT) REV. 1.0

Between **BALANCE SYSTEMS S.r.l.**
whose registered office is at **Via Roberto Ruffini 8/10 - 20090 Pessano con Bornago (MI) Italy**
represented by **Mr. STEFANO SENSOLI** (its Vice President)
(hereinafter called "The Manufacturer")

And **EUROSHILF**
whose registered office is at **Zavolnaya str., 17, room 2, office 4 - 142701 Vednoe Moscow region Russia**
represented by **Mr. Denis Belousov (G.M.)** (legal representative)
(hereinafter called "The Representative")

CONTRACT N° 01/2019

1/20

Balance Systems S.r.l.
Via Roberto Ruffini, 8/10 - 20090 Pessano con Bornago (MI) - Italy
P. I. n° 01210241503 - Tax n° 01210241503
www.balance-systems.com - info@balance-systems.com

Cap. Soc. € 500.000,00 - 02244 Milano 02/9509
Tel. +39 02 76591933 - Fax +39 02 76591977
www.balance-systems.com - info@balance-systems.com



Официальный сервисный центр
по ремонту шпиндельных узлов
производства компании GMN



GMN



GMN

Высокоскоростные шпиндельные узлы



Приводной
прецизионный
шпиндель



Инструментальный
шпиндель



Шпиндель
для автоматической
замены инструмента



Шпиндель
для ручной
замены инструмента

Обгонные муфты

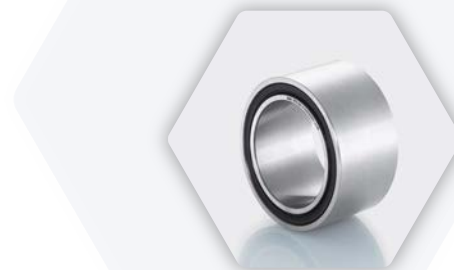

Комплексные



Подшипниковые



Встраиваемые
элементы

Высокоточные подшипники



Стандартная
программа
шпиндельные



Радиальные



Специальные



Подшипниковые
системы

Бесконтактные уплотнения



Форма CF



Форма S/SA



Форма L/M

Эксклюзивный представитель
компании Berg Spanntechnik –
механизмы зажима.



BERG
SPANNTÉCHNIK

The logo features a square icon on the left containing a stylized mechanical symbol, followed by the word 'BERG' in a large, outlined, sans-serif font, and 'SPANNTÉCHNIK' in a smaller, solid, sans-serif font below it.

Зажим инструмента



Специальные изделия



Зажим детали

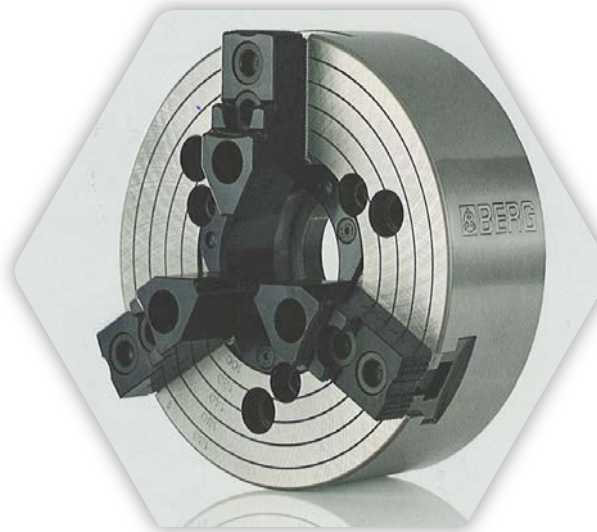

Формовочная техника

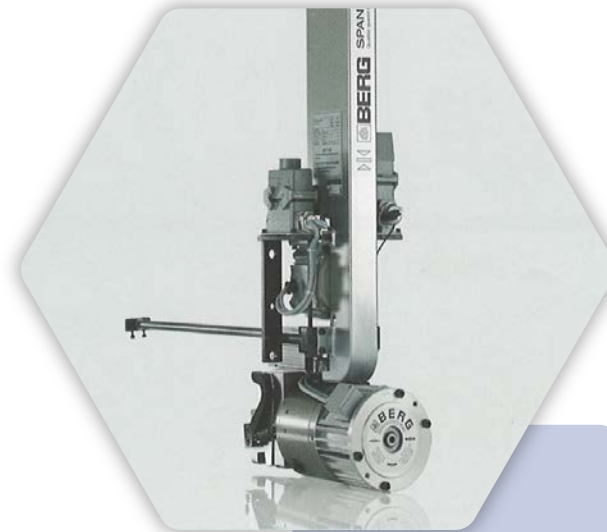

Представитель компании
Balance Systems



Balance
Systems

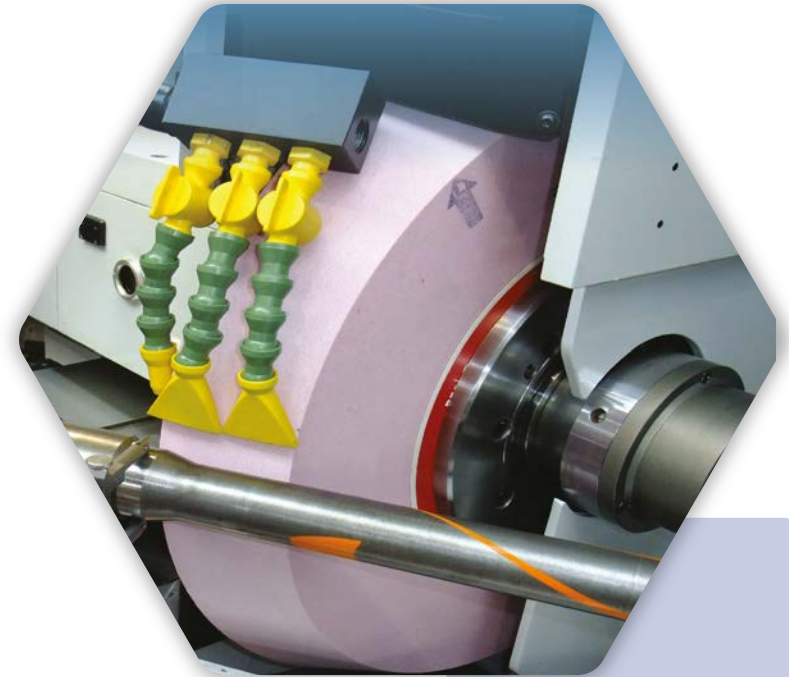
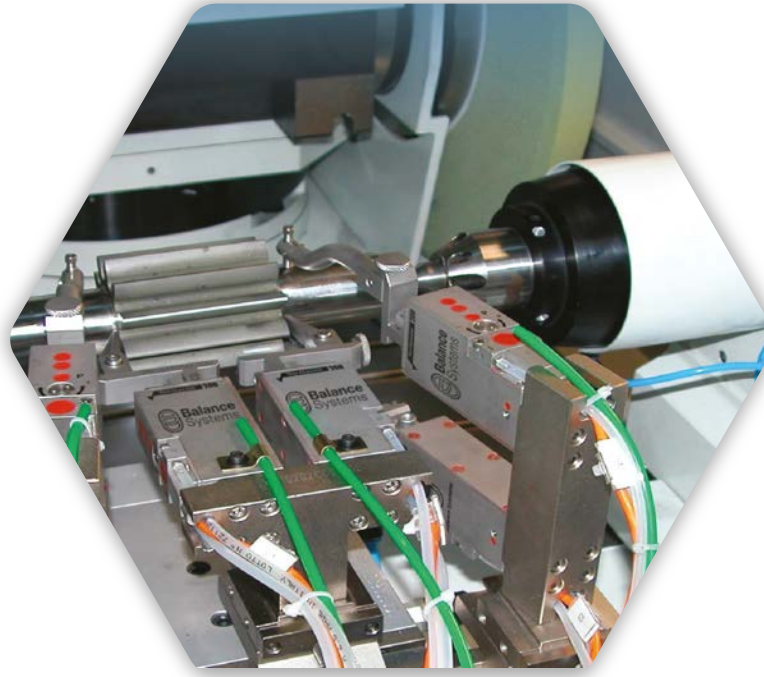
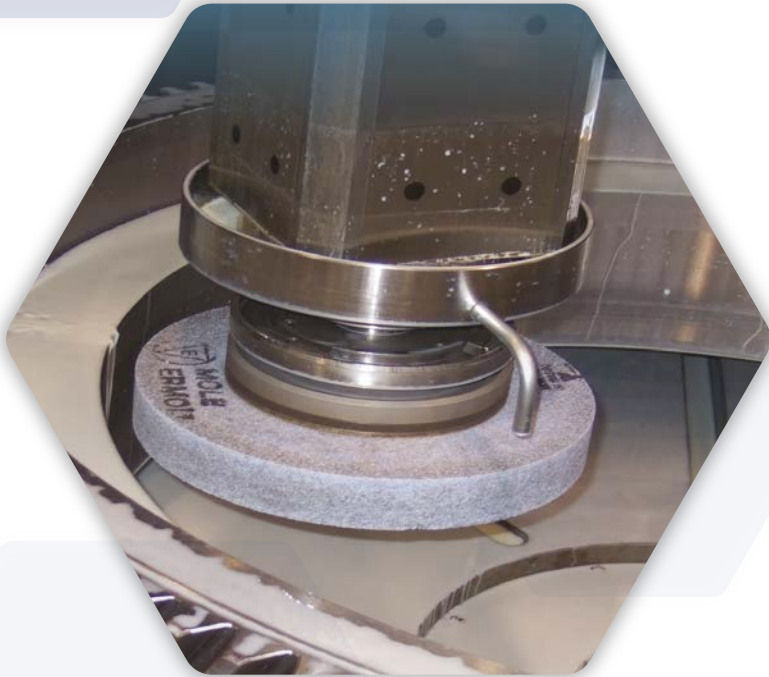

Подробнее о нашей работе
можете посмотреть в видео

